

# DHI-HWS800+

## Speed Measuring System



### System Overview

The speed measuring system adopts a fully embedded system with functions such as vehicle speed measurement, image capture, video surveillance, and automatic recognition of license plate number, lane, color, and vehicle model. Compared with traditional radar system that separates industrial PC and IP camera, the integrated system, combining the company's technical advantages in intelligent traffic field, offers users with stable performance, powerful functions, and ease of installation.

### Functions

#### Integrated and Compact Design, Easy to Install and Maintain

Integrates intelligent HD camera, control unit, LCD display, touch screen, power supply, speed measurement radar, and dedicated picture storage device, compact and attractive. Either portable or fixed, thanks to the integrated design.

#### Built-in Large-capacity SSD for Storing Pictures and Videos

The device can upload pictures to the central server for storage, backup, and viewing in real time, and supports 24-hour video recording or video footage of traffic violations for forensic evidence.

#### Capturing HD Pictures for Forensic Evidence

16 MP high-definition GS CMOS camera helps capture pictures of traffic violations. Information such as vehicle speed, capture time, capture location can be displayed on the pictures. With the watermark function, any tampering with the picture can be detected.

#### Multiple Networking Methods

Connects to network by using wired network and 3G/4G, reducing the requirements on installation locations.

- Monitors real-time conditions through LCD display or the web page of the device.
- Man-machine interaction interfaces facilitate user operations. High-performance radar helps quickly and accurately measure vehicle speed. The speed measurement range is adjustable between 5 km/h and 300 km/h.
- Multi-lane speed measurement.
- Speed measurement of ultra-low speed vehicles.
- Supports local SSD storage and ANR (automatic network replenishment). It overwrites pictures automatically when memory is insufficient.
- Supports traffic flow statistics by minute.
- Detection of traffic violations such as overspeed, underspeed, wrong-way driving, and more.
- Records vehicles with traffic violations, and links the captured picture to video.
- Data transmission, remote access and system maintenance are realized through Ethernet, 3G/4G, WIFI, and other technologies. You can also check the device operating temperature, operating status of major components, and more.
- NTP/GPS/BeiDou time synchronization; synchronization interval is adjustable; supports synchronizing with PC time.
- Images: Supports measurement date and time, measurement speed, measurement distance, measurement direction, speed limit, GPS location, operator code
- File: Supports XML import and export
- Technology: DOPPLER
- Protection: IP56
- Touch screen: Yes

#### Auto Calibration

Flexible parameter configuration, and automatic calibration of radar and video targets.

#### GPS/BeiDou Positioning

GPS/BeiDou positioning and time synchronization.

#### Multi-target Tracking and Recognition

Recognizes and tracks maximum 64 targets within 15 m–60 m (49.21 ft –196.85 ft).

### Sence

It is applicable to highways, city roads, and other scenarios that require speed measurement and traffic violations capture.

## Technical Specification

### Basic

Snapshot Resolution	16 MP, 5320 × 3032 pixels
Video Resolution	9 MP, 4096 × 2160 pixels
Image Sensor	1.1" GS CMOS
Transmission Mode	TCP/IP, FTP
Image Compression	JPEG
Video Format	H.265/H.264M/H.264H/H.264B/MJPEG
Video Frame Rate	1 fps–30 fps
Lane Coverage	1–4 lane(s)
Speed Measurement Range	5 km/h–300 km/h
Speed Measurement Accuracy	Simulated Speed Measurement Error Range: ± 1km/h
	On-site Speed Measurement Error Range: Vehicle speed <100 km/h: ±2km/h Vehicle speed ≥100 km/h: ±2%
Overspeed Capture Rate	≥95%
Radar Response Time	30 ms
Lane Recognition Rate	≥95%
Transmit Power	<20 dBm (100 mW)
Storage Capacity	1000 GB (standard), PCIe 2280 M.2 SSD
Radar Frequency	24.00 GHz–24.25 GHz
Beam Width	Horizontal: ±23° (–3 dB), Pitch angle: ±12° (–3 dB)

### Port

Data Ports	1 RS-232 port, 1 RS-485 port, 1 1000M Ethernet port, 1 USB3.0 port
Lithium Battery Port	1 port of 14.4 V 12.12 AH lithium battery
Power Input Port	1 24 VDC power input port
Power Output Port	1 12 VDC power output port, with maximum power of 12 W
Flash Sync Port	2 (digital quantity)
LED Strobe Sync Port	1
Lens Mount	C mount

### Capture Triggering Mode

Triggered by Radar	Yes
--------------------	-----

### Special Function

License Plate Recognition	≥95%
License Plate Cutout	Yes
Multi-target Tracking and Recognition	Recognizes more than 64 vehicles at distance of 15 m–60 m (49.21 ft–196.85 ft)
Positioning	GPS/BeiDou positioning
Composite Image	Yes, 1, 2, 3 or 4 snapshot (s) can be composited, and composition method can be selected

Image Wireless Transmission	3G/4G, WIFI
Mobile Network Frequency Band	FDD LTE: B1, B3, B5, B7, B8, B20, B28
Auto Registration	Yes
Automatic Network Replenishment (ANR)	Yes
Time Synchronization	Local/GPS/NTP
Speed Overlay	Overlays vehicle speed to the front or rear side of a vehicle in the video image
Video Storage	Records and stores videos of traffic violations by periods
Storage Space	Supports setting picture and video storage quota to ensure enough storage space of pictures
ICR Switch	Day/night ICR switch
Remote Control	Remote control through the web interface or the client
OSD Overlay	Supports overlaying date, time, location, plate number, plate color, model, vehicle speed, speed limit, radar direction, violation code, device No., anti-counterfeit code, and more
Watermark	Watermark verification on the web interface
Image Tampering Prevention	Yes. Watermark is available for pictures and videos

### Operating Environment

Operating Voltage	24 VDC; power adapter supports 100 VAC to 240 VAC, 50 Hz–60 Hz
Average Power Consumption	<25 W (in screen saver mode)
Operating Temperature	Lithium battery included: –20 °C to +60 °C (–4 °F to +140 °F)
	Lithium battery excluded: –40 °C to +65 °C (–40 °F to +149 °F)
Relative Humidity	20%–90% (RH, non-condensing)
Dimensions	238.0 mm × 196.0 mm × 277.6 mm (9.37" × 7.72" × 10.93") (L × W × H)
Weight	9.0 kg (19.84 lb)

## Ordering Information

Type	Model	Description
Speed Measuring System	DHI-HWS800+	Speed Measuring System
Illuminator	DHI-ITALF-300AD-IR	DHI-ITALF-300AD-IR IR flashing light (select one of the two)
	DHI-ITALF-300AD	DHI-ITALF-300AD white flashing light (select one of the two)
Cabinet (fixed)	DHI-BXH01M2	Vandal-proof cabinet components
Bracket (fixed)	PFA162	Illuminator bracket
Bracket (mobile)	GA258F	Tripod for speed measuring system
	Benro A-214	Tripod for flashing light

## Installation

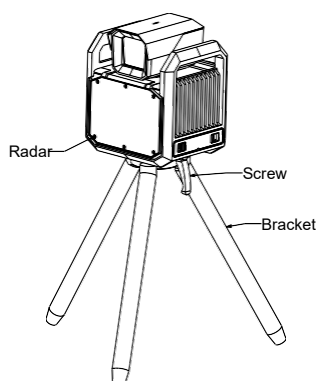

## Dimensions (mm[inch])

