

REVISIONS				
ZONE	REV	DESCRIPTION	DATE	APPROVED
	A	技術轉移單 EG06011	02/08'06	Sam Lee

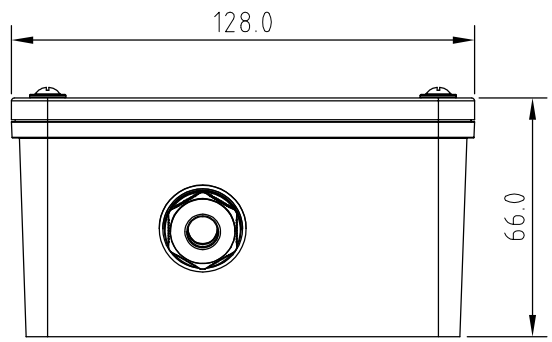
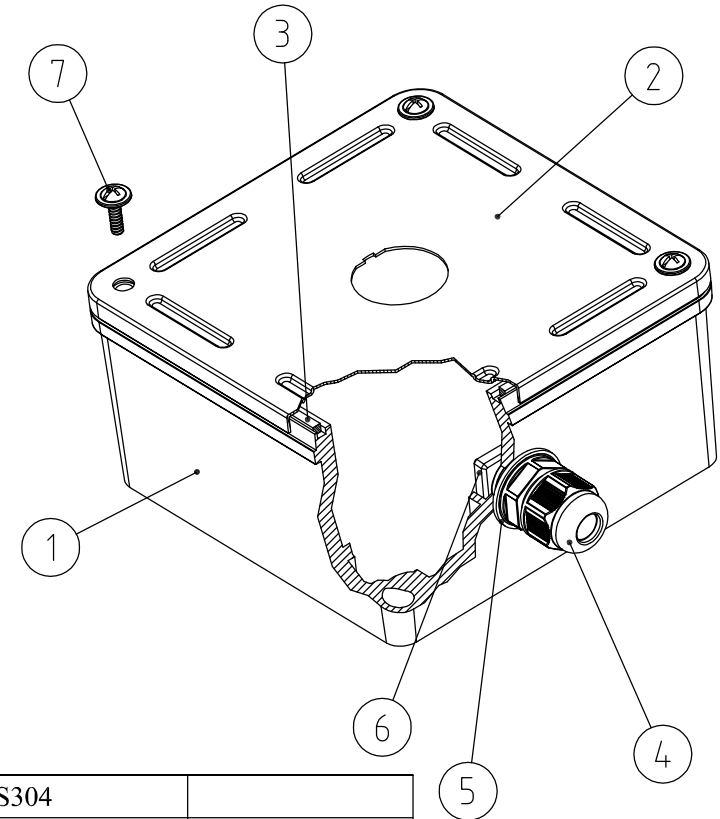
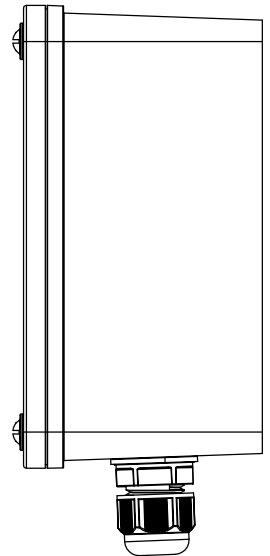
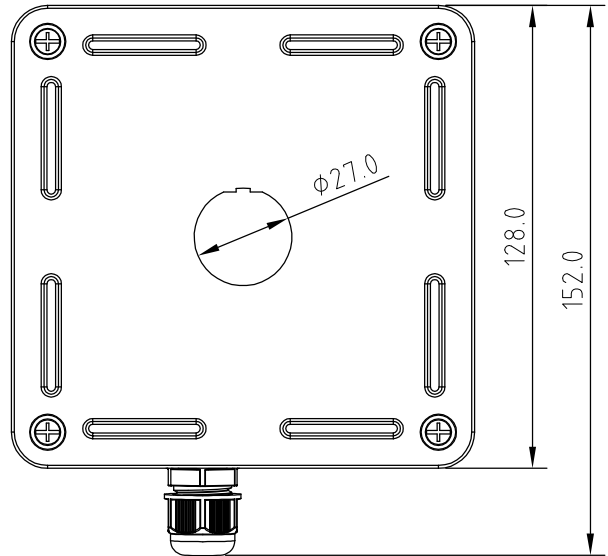

⑦	Screw to fix the cover	SUS304	
⑥	Waterproof sealing screw nut	Nylon + 30% GF	
⑤	Waterproof sealing gasket	EPDM	
④	Waterproof sealing cover	Nylon PA66	UL 94V-2
③	Gasket	Rubber	
②	Cover	SUS304	
①	Box	Polyac ABS	UL 94V-0
NO.	Description	Material	Flame retardancy

UNLESS OTHERWISE SPECIFIED: TOLERANCES			PROJECT ID		EUFOLAN	
INCH	MM	ANGULAR	12B-01-67WT		FILE	
.X ± .016	.X ± 0.2	X ± 1°			Z 2043 .dwg	
.XX ± .008	.XX ± 0.1	.X ± .5°			DATE	TITLE
.XXX ± .004					02/08'06	IP 67 BOX, 1port
MATERIAL			DRAWN	Sam	SCALE	
SURFACE			CHECK		NON	UNIT mm
FINISH			APPROVED		SHEET	1 OF 4