

REVISIONS				
ZONE	REV	DESCRIPTION	DATE	DRAWN
	A	工新字EG16018號	03/25'16	NICK
	B	造型設變,ECN:ME16411	09/29'16	NICK

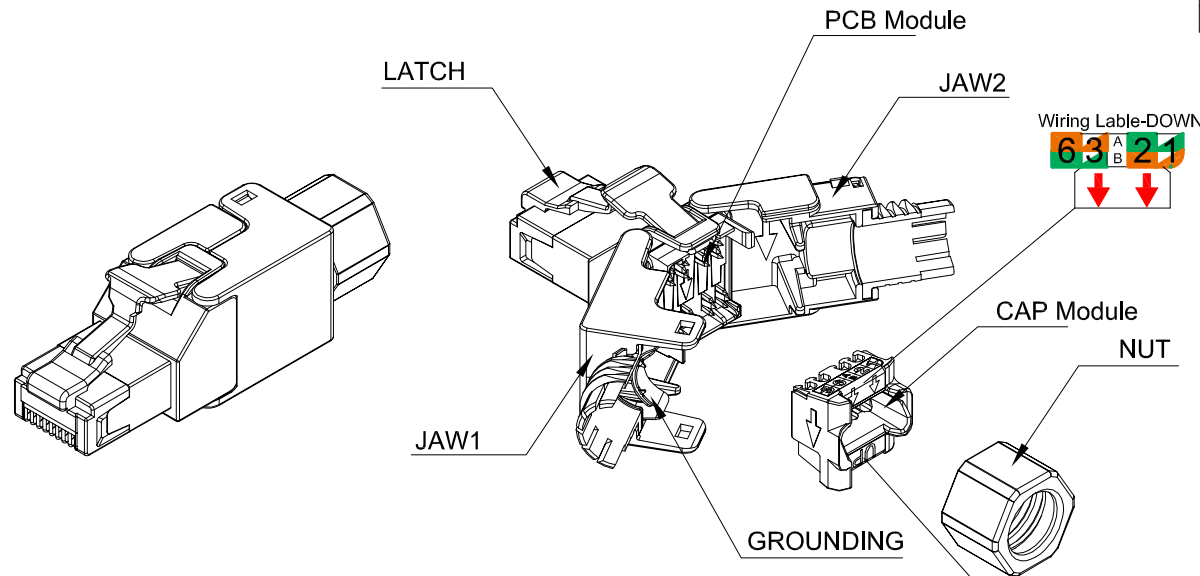

COMPONENTS		
ITEM	PART NAME	Q'TY
1	PCB Module	1
2	LATCH	1
3	GROUNDING	1
4	JAW1	1
5	JAW2	1
6	CAP Module	1
7	NUT	1
8	Wiring Lable-DOWN	1
9	Wiring Lable-UP	1

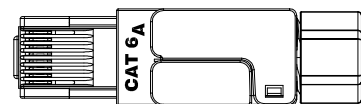
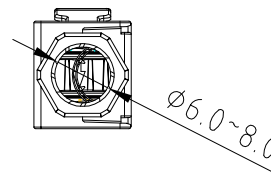
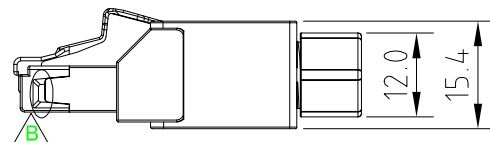
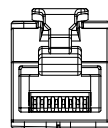
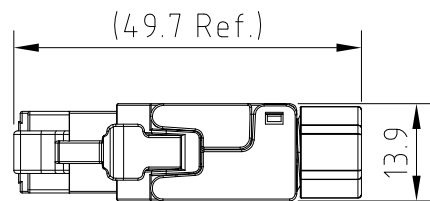

**TRANSMISSION PERFORMANCE**  
 Meet all requirements specified in Patch Cord requirement of ISO/IEC 11801, Category 6A

**ELECTRICAL**

Electrical Insulation Resistance : 500MΩ min. @100V d.c  
 Dielectric Withstanding Voltage : 1000V D.C or A.C Peak,  
 Contact to Contact;1500V D.C or A.C Peak,  
 Contact to Shield@ 60Hz for 1 Minute.

**MECHANICAL**

IDC Wire Gauge : 23 ~ 26 AWG

**PHYSICAL**

Housing : Zinc-alloy fully shielded  
 Contact pin : Phosphor Bronze Alloy Plated With 50 micro-inch of Gold  
 IDC : Phosphor Bronze Alloy With 100 micro-inch 100% Sn Alloy

UNLESS OTHERWISE SPECIFIED: TOLERANCES		PROJECT ID 13A-EA-03SL	<b>EUROLAN</b>	
INCH .X ± .016 .XX ± .008 .XXX ± .004	MM .X ± 0.2 .XX ± 0.1 .X ± .5	ANGULAR X ± 1° X ± .5°	FILE Z4203.DWG	DATE 03/24'15
MATERIAL		DRAWN NICK	TITLE CAT 6A FIELD TERMINABLE PLUG	
SURFACE		CHECK	SIZE A4	DRAWING NUMBER Z4203
FINISH		APPROVED	PART NUMBER	REV B
SCALE 1:1		UNIT mm	SHEET 1 OF 1	