

**Transmission Performance:**

Meet all requirements specified in connecting hardware requirement of TIA/EIA-568-B.2 Cat.5e.

**ELECTRICAL**

Electrical Insulation Resistance : 500 MΩ min. @ 100V d.c.  
 Dielectric Withstanding Voltage :  
 1000V d.c. or a.c. Peak Contact to Contact @ 60Hz for 1 minute.  
 Spring Wire Contact Resistance : 20 mΩ Max.  
 IDC Contact Resistance : 2.5 mΩ Max.  
 Current Rating : as figure.

**MECHANICAL**

Retention : 50N (11 lbf) for 60s±5s  
 Insertion / Extraction Life : 750 Cycles Minimum  
 IDC Wire Gauge : 22 ~ 24 AWG

**PHYSICAL**

Housing : High-Impact, Flame-Retardant Plastic, UL 94V-0  
 Spring Wire : Phosphor Bronze Alloy Plated With 50 micro-inch of Gold Over 70 min.  
 micro-inch of Nickel (50 micro-inch Gold Plating only in Contact Area).  
 IDC Terminal : Phosphor Bronze Alloy Plated With 100 min. micro-inch Tin.

International Protection Code meet IP67

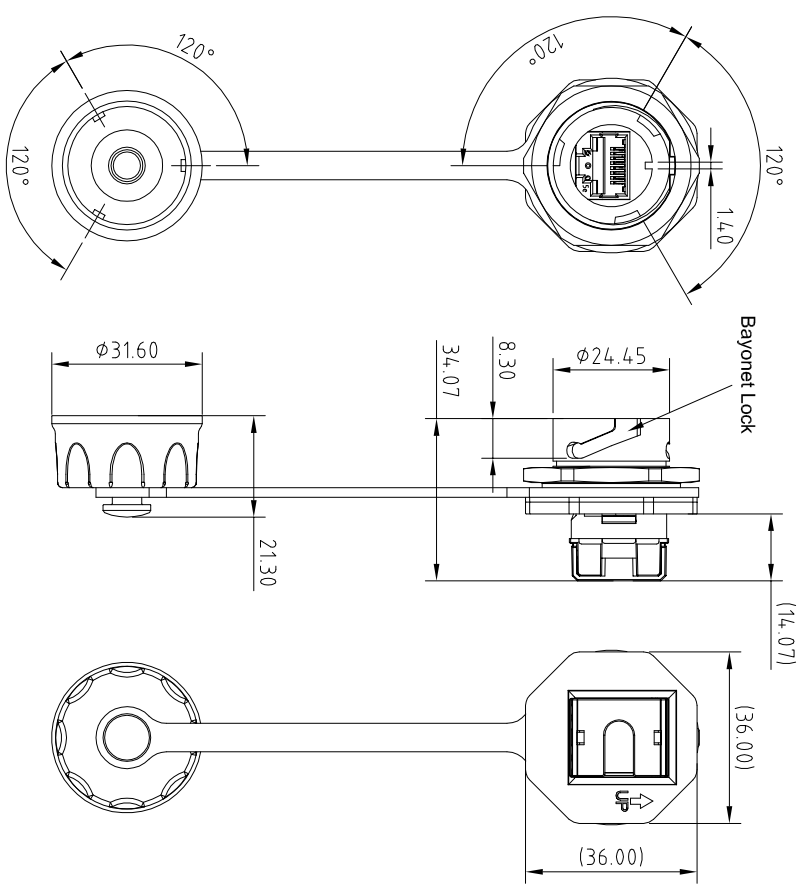
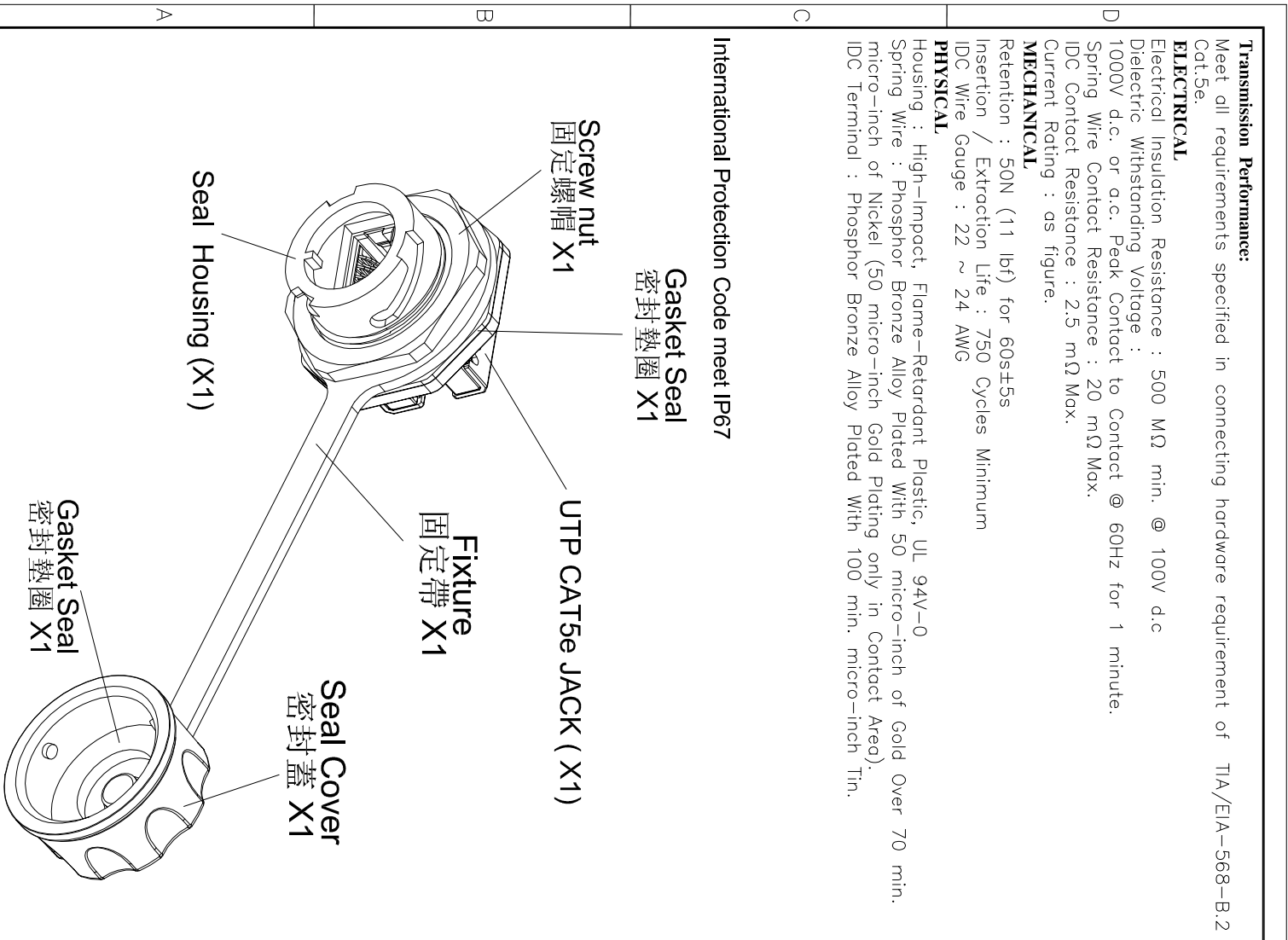

| ZONE |   | REV         | DESCRIPTION | DATE       | DRAWN       |
|------|---|-------------|-------------|------------|-------------|
|      | A | EG04067     | 新產品技術移轉     | 11/17/2004 | JACKY HUANG |
|      | B | ECN ME07452 | 去除正扭力敘述     | 12/19/07   | Alan        |

REVISIONS  
1

|                             |  |             |  |                             |  |
|-----------------------------|--|-------------|--|-----------------------------|--|
| UNLESS OTHERWISE SPECIFIED: |  | PROJECT ID  |  | TITLE                       |  |
| INCH TOLERANCES             |  | 168-U5-67BL |  | IP 67 C5E UTP keystone jack |  |
| X ± 0.16                    |  | FILE        |  | SIZE                        |  |
| XX ± 0.05                   |  | Z1717.DWG   |  | DRAWING NUMBER              |  |
| XXX ± 0.02                  |  | DATE        |  | PART NUMBER                 |  |
| ANGULAR                     |  | 11/17/2004  |  | Z1717.DWG                   |  |
| X ± 0.2                     |  | DRAWN       |  | REV                         |  |
| X ± 0.1                     |  | JACKY HUANG |  | B                           |  |
| X ± .5                      |  | CHECK       |  | SCALE                       |  |
| SURFACE                     |  | APPROVED    |  | 1:1                         |  |
| FINISH                      |  |             |  | UNIT                        |  |
|                             |  |             |  | MM                          |  |
|                             |  |             |  | SHEET 1 OF 1                |  |

