

## DH-PTZ35220S-IRA-N

---

### 2 Megapixel Full HD Network Mobile Positioning System



#### Features

- 2Mp excellent image quality
- Powerful 20x optical zoom
- Pan range: 360° endless, speed up to 60°/s
- Up to 300 Presets, 4Tour, 4Pattern, 4Auto scan
- IR Distance up to 150m
- Multiple network monitoring: Web viewer, CMS(DSS/PSS) & DMSS
- DC8V~36V Power Supply
- IP66

## DH-PTZ35220S-IRA-N

### Technical Specifications

<b>Model</b>	<b>DH-PTZ35220S-IRA-N</b>
<b>Camera</b>	
Image Sensor	1/2.8" Exmor CMOS
Effective Pixels	1944(H) x 1092(V), 2 Megapixels
Scanning System	Progressive
Electronic Shutter Speed	1/1 ~ 1/30,000s
S/N Ratio	More than 50dB
Day/Night	Auto(ICR) / Color / B/W
Backlight Compensation	BLC / HLC /DWDR
White Balance	Auto, ATW, Indoor, Outdoor, Manual
Gain Control	Auto / Manual
Noise Reduction	2D / 3D
Digital Zoom	16x
<b>Lens</b>	
Focal Length	5.5mm ~ 110.0mm(20x Optical zoom)
Max Aperture	F1.6~F3.5
Focus Control	Auto / Manual
FOV-H	H: 51°~2.6°
<b>Video</b>	
Compression	H.264 / MJPEG
Resolution	1080P(1920×1080) / 720P(1280×720) / D1(704×576/ 704×480) /CIF (352×288/352×240)
Frame Rate	Main Stream:25/30fps@1080P /720P Sub Stream: 25/30fps@D1/CIF
Bit Rate	H.264: 56K ~ 8192Kbps, MJPEG: 56K ~ 20480Kbps
<b>Network</b>	
Ethernet	RJ-45 (10/100Base-T)
Protocol	IPv4/IPv6, HTTP, HTTPS, SSL, TCP/IP, UDP, UPnP, ICMP, IGMP, SNMP, RTSP, RTP, SMTP, NTP, DHCP, DNS, PPPOE, DDNS, FTP, IP Filter, QoS, Bonjour
ONVIF	ONVIF Profile S
Max. User Access	20 users
Smart Phone	iPhone, iPad, Android, Windows Phone
<b>Pan/Tilt System</b>	
Pan Range	360° endless
Pan Speed	0.1° ~ 60°/sec;
Tilt Range	-90° ~ 90°
Tilt Speed	0.1° ~30°/sec
Positioning Accuracy	±0.1°
Preset	300

## DH-PTZ35220S-IRA-N

Tour	4
Pattern	4
Auto Scan	4
Preset Auto-Calibration	Support
Remote P/T/Z Reset	Support
Wiper	Support
IR Distance	150m
<b>Audio</b>	
Compression	G.711a / G.711u(32kbps)/ PCM(128kbps)
Interface	1/1 channel In/Out
<b>General</b>	
Power Supply	DC 8V~36V
Power Consumption	<60W
Working Environment	-30°C ~ 65°C / Less than 90% RH
Protection	IP66, All-metal aluminum alloy, 6000V anti-lightning surge
Weight	8.5Kg;

# DH-PTZ35220S-IRA-N

## Dimensions (mm)

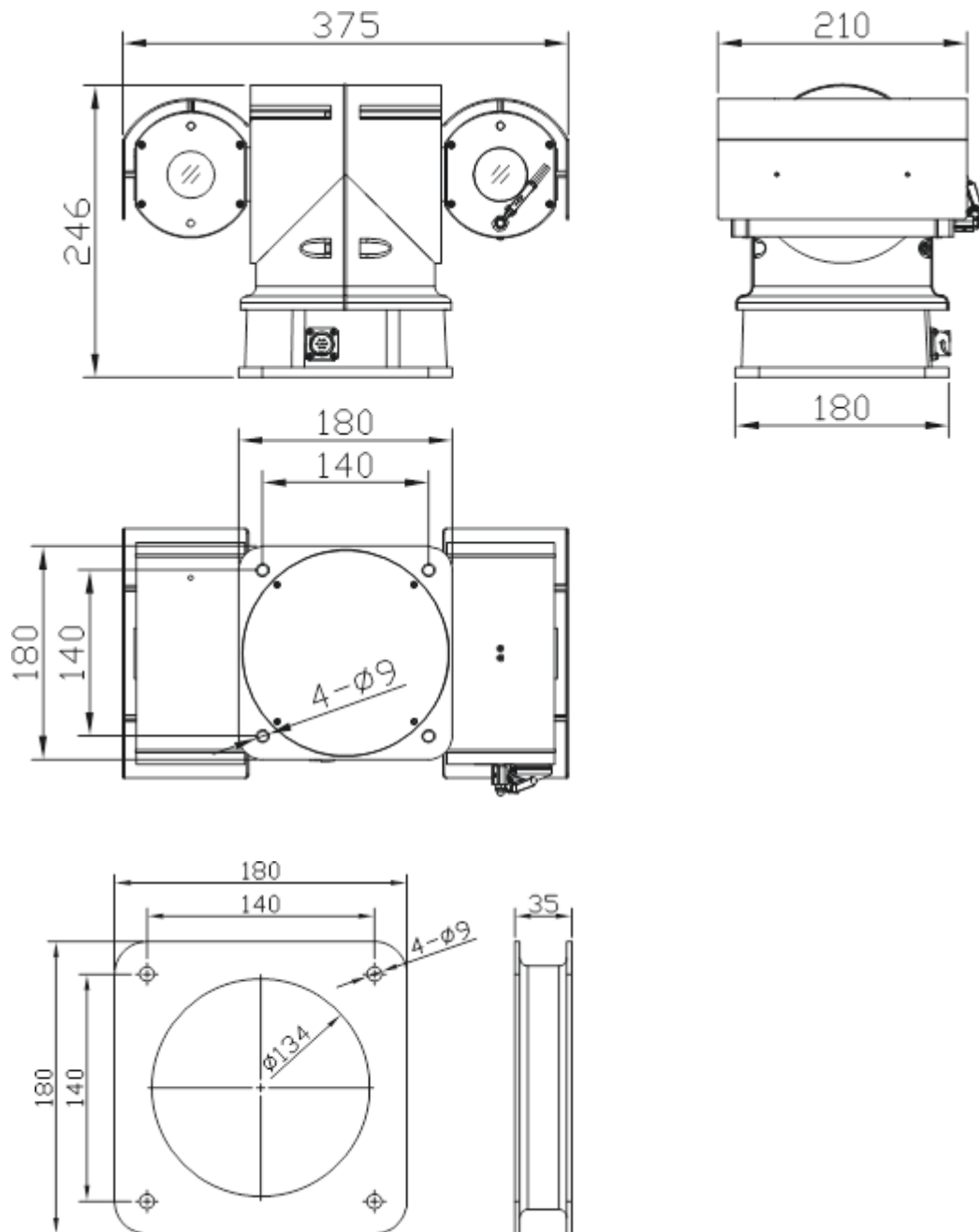

### Dahua Technology Co., Ltd.

1187BinAn Road, Binjiang District, Hangzhou, China

Tel: +86-571-87688883

Fax: +86-571-87688815

Email: [overseas@dahuatech.com](mailto:overseas@dahuatech.com)

[www.dahuatechsecurity.com](http://www.dahuatechsecurity.com)

\*Design and specifications are subject to change without notice.

© 2013Dahua Technology Co., Ltd.